

i-vac co-botic™ 1700

Smart, Autonomous Vacuum

User manual



i-team Professional B.V.

Hoppenkuil 27b, 5626 DD Eindhoven, The Netherlands

Telephone: +31402662400

Email: hello@i-teamglobal.com

Internet: www.i-teamglobal.com

*optional Automatic Dirt Disposal system pictured





Original user manual, written in the English Language

Future Cleaning Technologies B.V.

Hoppenkuil 27b, 5626 DD Eindhoven, The Netherlands

Telephone: +31402662400

Email: hello@i-teamglobal.com

Internet: www.i-teamglobal.com

Model: co-botic™ 1700

Product code: COB17N.FCT.0230A

Date: 14/02/2022

Version: v.1.0



FASTER

I am faster because I keep working nonstop for 270 minutes. After recharging I'll be up and running again for the next cleaning round.



CLEANER

I keep going while you programmed me, I can program myself for the highest possible clean. Or I can follow your instructions.



GREENER

I am programmed to do the vacuuming as precise and efficiently as possible. Every bit of my energy is used for cleaning... nothing wasted. Where I am using 50W. in one hour, several alternatives are using 1000W



SAFER

No cables means the reduce of falling hazard. Even to be used overnight in dark areas without any trouble.



BETTER FOR EVERYONE

You are able to do other tasks in the meantime. You keep the trained human eye that will last to perfection. You can focus on the details.



Preface

Thank you for choosing co-botic™ 1700, the device designed for quick, autonomous cleaning of small spaces.

The co-botic 1700 is easy to use when you follow the instructions. Please read the user manual carefully. Become familiar with the correct operation and maintenance procedures. Store the manual in a safe place. The manual is an essential part of the co-botic 1700 and must be handed over to the new owner upon resale or exchange. Each co-botic 1700 has a unique serial number that can be found on the bottom of the main body. Your i-partner needs this number when you order parts.

When this manual refers to “the manufacturer” this means: Future Cleaning Technologies B.V., an affiliate company of i-team Professional in Eindhoven, the Netherlands. When this manual mentions “the partner” your local i-team reseller and support service partner is referred to.

Purpose of the user manual

The purpose of the user manual is to provide the user with information during the life of the co-botic 1700 in such a way that the co-botic 1700 is used correctly, efficiently and safely, even in the event of reasonably foreseeable misuse.

The user manual contains instructions regarding:

- personal operator safety;
- intended and non-intended use of the co-botic 1700;
- instructions for daily use;
- maintenance instructions;
- storage conditions;
- disposal of the co-botic 1700.

These instructions must be considered to avoid risks that could lead to physical and/or material damage.

Target audience

This user manual is intended for operators of the co-botic 1700 and their supervisors, as well as partners and importers.





Operators of the co-botic 1700

The co-botic 1700 may only be operated by a person who has correctly read and understood the instructions in this manual or is trained by an experienced operator who has read and understood the instructions in this manual.



Reading guide

The following symbols and terms are used throughout this manual to alert the reader to safety issues and important information:

| Symbol | Term | Explanation |
|---|-----------|--|
|  | WARNING | Indicates a hazardous situation which, if the safety instructions are not followed, can lead to injuries of the operator or bystanders, light and/or moderate damage to the product or the environment. |
|  | CAUTION | Indicates a hazardous situation which, if the safety instructions are not followed, can lead to light and / or moderate damage to the product or the environment. |
|  | BATTERIES | Indicates a battery-operated machine, batteries must be charged according to the instructions in the separate Class I Battery Charger user manual. Batteries must be disposed of according to your local laws and regulations. |
|  | ATTENTION | Indicates a liability situation, where the manufacturer or its partners and affiliates cannot be held accountable for damages caused by non-compliance. |



Content

| | |
|--|----|
| Preface | 4 |
| Purpose of the user manual..... | 4 |
| Target audience..... | 4 |
| Operators of the co-botic 1700 | 4 |
| Reading guide | 5 |
| 1 Introduction | 8 |
| 1.1 Intended use of the product..... | 8 |
| 1.2 Non-intended use of the product..... | 8 |
| 1.3 Lifespan | 8 |
| 1.4 Modifications | 8 |
| 1.5 Specifications | 9 |
| 1.6 Warranty..... | 9 |
| 1.7 Identification | 9 |
| 2 Description | 10 |
| 2.1 Buttons and Sensors..... | 11 |
| 3 Safety..... | 11 |
| 3.1 Battery | 12 |
| General precautions..... | 12 |
| Health hazards..... | 12 |
| 4 Transport and storage | 13 |
| 5 Assembly and installation..... | 13 |
| 5.1 Installation..... | 13 |
| 5.2 Install the charger base..... | 13 |
| 6 Operation | 14 |
| 6.1 Using the co-botic 1700 without an app..... | 15 |
| 6.2 Using the co-botic 1700 with an app..... | 15 |
| 6.3 Registering and Logging in..... | 15 |
| 6.4 Connecting the co-botic 1700 to the network and the app..... | 16 |
| 6.5 Setting up your organization | 18 |
| 6.6 Sharing the co-botic 1700 with multiple users..... | 18 |
| 6.7 Mapping and routes..... | 19 |



| | | |
|------|--|----|
| 6.8 | Creating rooms, no-go zones and cleaning modes | 20 |
| 6.9 | Using the cleaning buttons..... | 22 |
| 6.10 | Other features..... | 22 |
| 7 | Maintenance | 24 |
| 7.1 | Cleaning | 24 |
| 7.2 | Damaged or worn parts..... | 24 |
| 7.3 | Maintenance frequency..... | 24 |
| 7.4 | Storage | 24 |
| 8 | Trouble shooting..... | 25 |
| 9 | Decommissioning and disposal | 26 |
| 10 | Specifications | 26 |



1 Introduction

The co-botic™ 1700 is an easy and safe device to use. This manual helps you get started and explains the operation and maintenance procedure.

The battery should be fully charged before use. You can do this by placing the device onto its charging station. Please refer to your i-partner for more information on chargers.

This manual is intended for those who work with the co-botic 1700 and perform daily maintenance. The manual must be read in full before the first actions. This manual describes the correct method of use, safety measures, maintenance and transport.

i-team continuously improves all its products based on user experience and feedback. Any deviations between the texts and/or images from the manual and your product can therefore arise from a difference in model or from possible changes due to continuous development and innovation.

1.1 Intended use of the product

The co-botic 1700 is specially developed to vacuum small spaces in commercial environments. For example: in hotels, schools, hospitals, factories, shops and offices. It is intended for use indoors and in a dry environment only.

1.2 Non-intended use of the product



WARNING

Non-intended use can have consequences for the safety of operators and bystanders and will void the warranty on the product.

For a longer lifespan of the co-botic 1700, clean it and check it for damage after each use.

1.4 Modifications

It is not permitted to make modifications to the design of the co-botic 1700 without consultation and permission from the manufacturer. This affects the warranty, see section 1.6.



1.5 Specifications

| | |
|---------------------------------|---------------------------|
| Model: | Co-botic 1700™ (basic) |
| Body size (L x W x H): | 350 x 350 x 98 mm |
| Weight (excl. battery): | Not applicable |
| Weight (incl. battery): | 3.4 kg |
| Power source: | 220V docking station |
| Battery spec i-power x: | Not applicable |
| Run time on battery: | 270 minutes |
| Charger type: | Docking |
| USB-C charging (5 V 2 A) time : | ≈ 240 minutes |
| i-charge 5 time: | Not applicable |
| i-charge 7 time: | Not applicable |

1.6 Warranty

The co-botic 1700 should only be used as intended and described in this manual. Using the co-botic 1700 in any other way will void the manufacturer's warranty. The warranty period is 1 year.

1.7 Identification

Each co-botic 1700 has a unique serial number that can be found on the bottom of the main body. Your i-team partner needs this number when you order parts.

Explanation type plate:

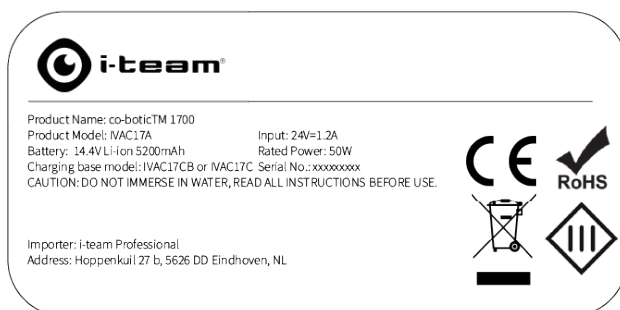

Product type: co-botic 1700
 Product model: Specific to the version of the co-botic 1700
 Serial number: Needed for warranty claims
 Charging base model: Which bases work for your model

Importer:
 i-team Professional
 Hoppenkuil 27 b
 5626 DD Eindhoven
 The Netherlands



2 Description

The co-botic™ 1700 consists of:

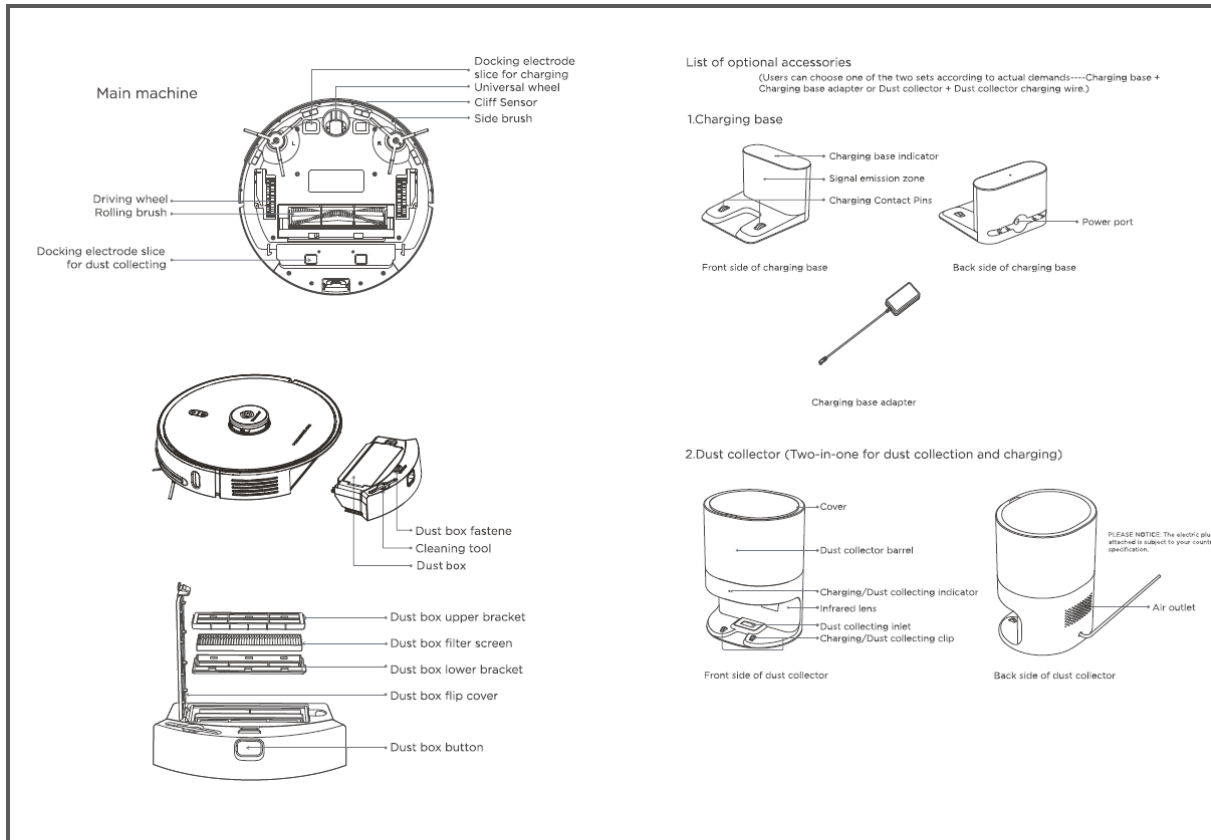
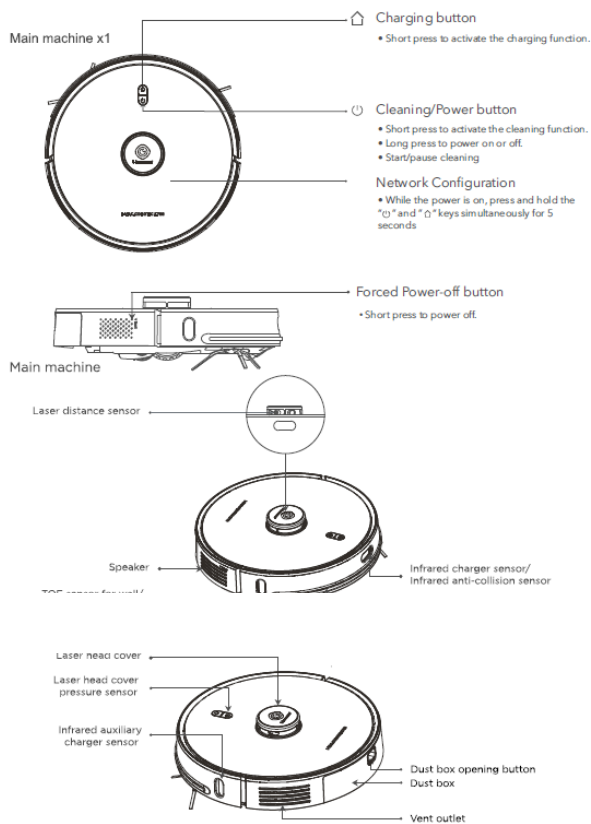

Figure 2

1. Main machine
2. Dust box
3. Dust filter
4. Cleaning tool
5. Extra side brushes
6. Remote control
7. Batteries
8. Charging base
9. Power cable



2.1 Buttons and Sensors



3 Safety

Safety comes first. Therefore, please take time to read and understand these safety instructions. Improper use can cause harm or void the manufacturer's warranty.



WARNING

STOP OPERATION IMMEDIATELY if the co-botic™ 1700 does not perform properly or makes an unusual noise. Service the co-botic 1700 before you continue the operation.



WARNING

DO NOT use the co-botic 1700 on damp or wet surfaces. This will cause damage to the co-botic 1700 and is dangerous to the user. The damage caused by the use on a wet surface is not covered under the warranty.



3.1 Battery

General precautions

CAUTION



- Do not use in an environment where the temperature is above 40°C or below 0°C
- Do not use in an environment with any liquid or viscous substances
- Do not let children or otherwise unqualified people use the device
- Keep body parts away from the suction inlet of the machine when it is running
- Do not use it to clean any burning objects (such as lit cigarettes)
- Do not use it for suction of hard or sharp objects (such as glass, steel, nails, etc.)
- Do not transport or move the cobot by using the cover of the Lidar, the cover of the machine, or the impact bumper as the handle
- Shut the machine down before cleaning or maintaining the machine and charging base
- Do not wipe any part of the product with an overly wet cloth or liquid
- Use the product in accordance with the instruction manual. Any loss or damage caused by improper use is the user's own responsibility
- Do not incinerate the product even if it has been severely damaged, the battery inside may explode

Health hazards

WARNING

If exposed to any of the battery pack chemicals, please follow the procedures below:

Eyes - Flush the eyes with plenty of water for at least 15 minutes, holding the upper and lower eyelids open from time to time.



Inhalation - Leave the area in which the contact occurred immediately and seek fresh air. Use oxygen if available.

Ingestion - Give the person at least two glasses of milk or water. Induce vomiting if the patient is conscious. Seek medical attention.

- Do not use any third-party batteries, chargers, and charging bases
- Do not disassemble, repair or modify the battery or the charging base
- Do not place the charging base near a heat source (such as a radiator)
- Do not discard inactive batteries, dispose in professional recycling facilities



- If the power wire is broken, stop using the machine immediately
- For transport/return, turn off the machine and use the original packaging

4 Transport and storage

- do not store the co-botic™ 1700 outdoors;
- store the co-botic 1700 only in a dry place;
- if applicable, fully charge the battery before using the co-botic 1700 again

5 Assembly and installation

The co-botic 1700 does not require assembly. The co-botic 1700 can be used with a standard docking station (included), or with the Automatic Dirt Disposal system (not included). The standard docking station will require the user to empty the dirt collection bin in the cobot itself on a regular basis. When using the Automatic Dirt Disposal system, the cobot will empty it's bin into the larger disposal bag. The frequency of this can be changed in the app.

5.1 Installation

The co-botic 1700 is packed in 1 box together with a USB cable and a wall plug. You must first remove the foam transportation pieces between the front bumper and the main unit.

5.2 Install the charger base (standard)

1. Place the charger base flat against a wall, do not leave a gap

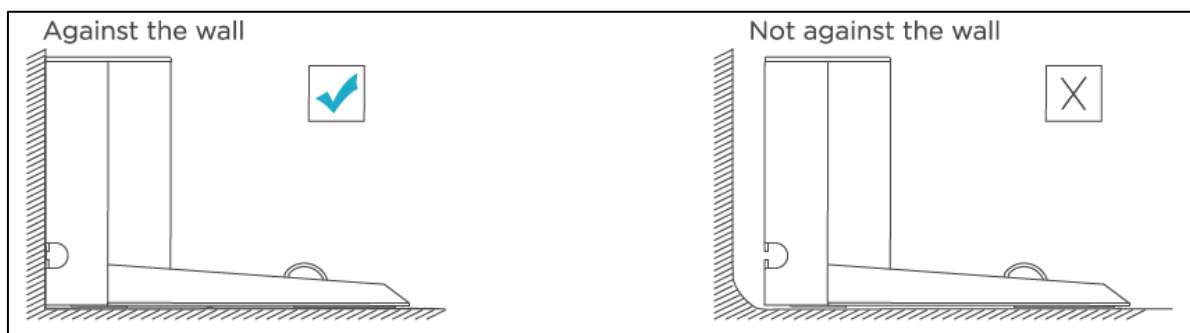



2. Ensure that there is more than 1.2 meters of empty space in front of the charger and more than 0.5 meters of empty space to the side.

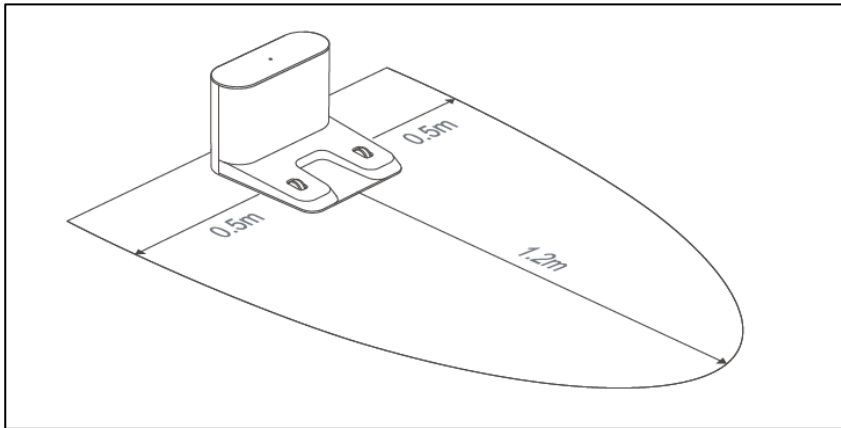

6 Operation

1. Place the co-botic™ 1700 on the floor in front of the charger base
2. Long press the power button 
3. The cobot will find it's charging base and begin to charge

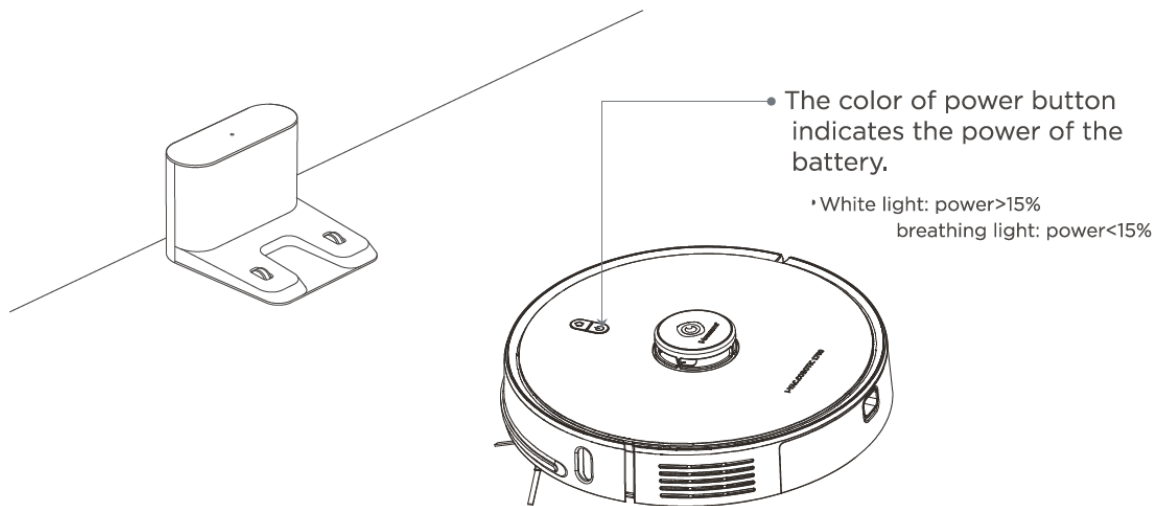

Note: When the power is insufficient, it may not be able to turn on. Please dock the machine on the charging clip of the charging base. The orange light of the power button will be always on when charging.



ATTENTION

Fully charge the battery the first time you use the co-botic 1700.



6.1 Using the co-botic™ 1700 without an app

1. Quick press the power button
2. The co-botic 1700 will begin cleaning the space it is in
3. While it is cleaning it will also build a map of the space that can be used later with the app
4. After cleaning, the cobot will return to it's charging base
5. NOTE: If the hotel version of software is installed on the device, the cobot WILL NOT return to it's base, instead it will return to the position where it was first started.
6. Press the home button to manually tell the cobot to return to it's base

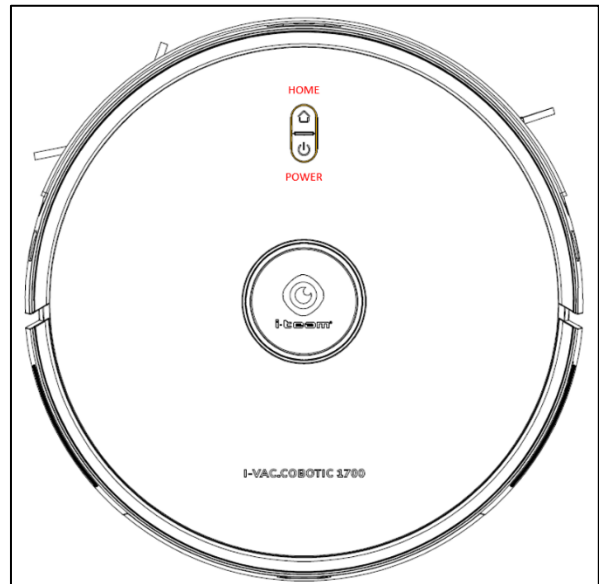

6.2 Using the co-botic 1700 with an app

Using the co-botic 1700 with an app will allow you to:

- Map and route your space
- Make rooms and no-go zones
- View the results from your cleaning
- Check your overall cleaning statistics
- Add multiple spaces and cobots
- Add other users to your cobots
- Check the consumables levels
- See error messages

6.3 Registering and Logging in

1. Download the “Co-botic” app from the Apple Store or the Google Play store by performing a search in the store or by scanning the QR code below:



2. Register with your email address for a new account (skip step 2 and 3 if you already have an account)
3. Select your country
4. Log in with your new account into the app
5. This will be your “Profile” for connecting to multiple machines later on



6.4 Connecting the co-botic™ 1700 to the network and the app

1. Power on the device
2. If the “POWER” button is flashing blue, then the machine is ready to connect
3. If they are not blinking, then press both “HOME” and “POWER” buttons together for 3 seconds. The cobot will then say “WiFi connection reset”
4. Ensure that your mobile device is connected to a 2.4Ghz wireless network. (We do not currently support 5Ghz wireless networks)
5. On the app, select “Add device”
6. Choose the “co-botic 1700” device

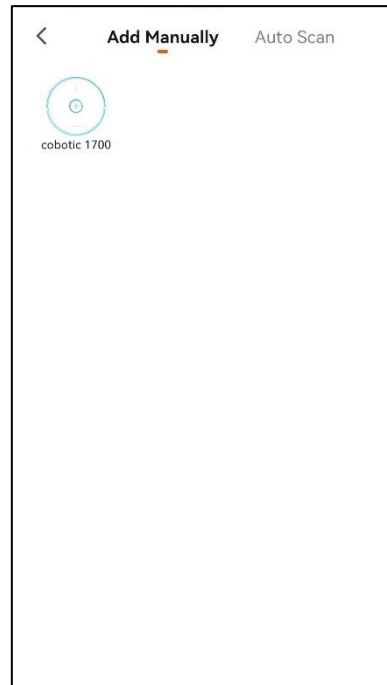
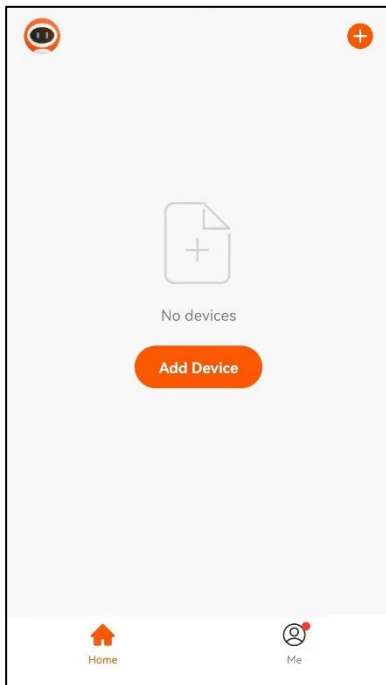

7. Select your own wireless network in the list and enter the password
8. Ensure once again the “POWER” light is flashing blue on the co-botic 1700 device, then tick the box for “Confirm power on key blue slow flash”
9. Connect to the wireless network of the co-botic 1700 by selecting the network “Smartlife-xxxxxxx”
10. The app will then start connecting the cobot to your network
11. When it is complete, click “Done” and the connection is successful

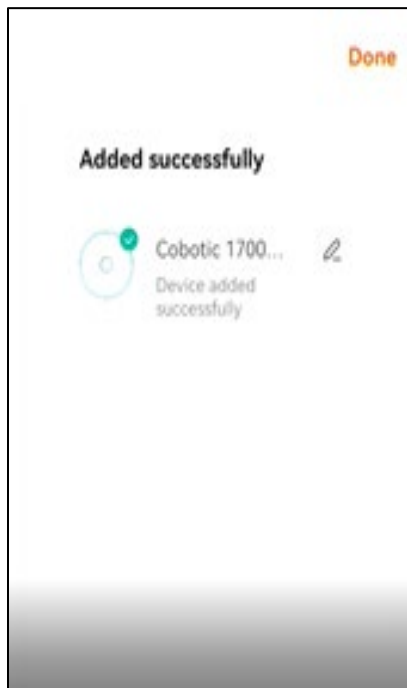
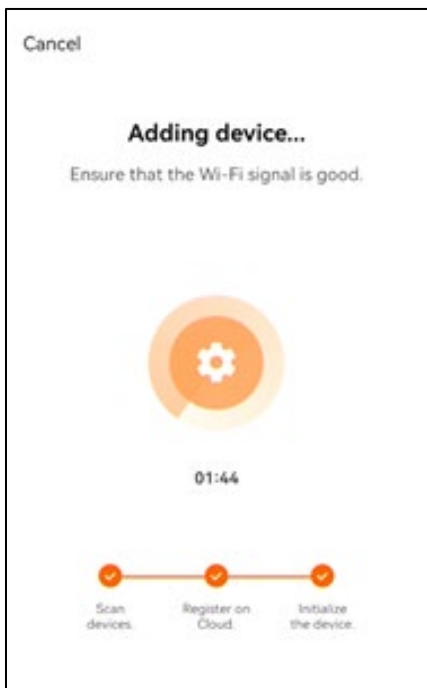
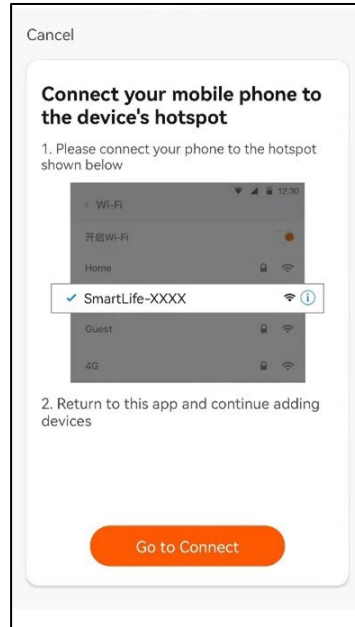
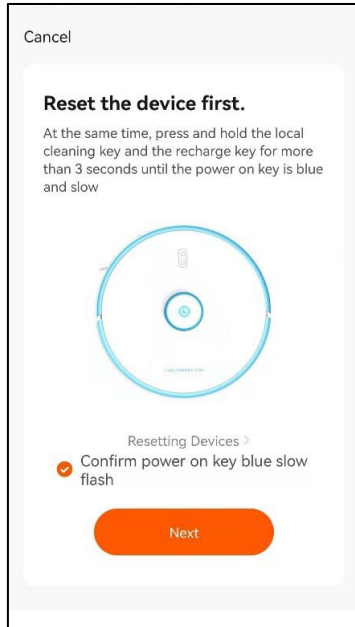
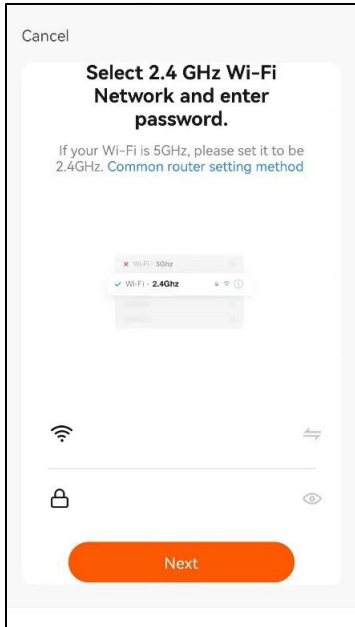



6.5 Setting up your organization

The co-botic™ 1700 is capable of being placed into an organization with multiple buildings, rooms, and cobots. How you set up your organization is critical to identifying where the cobots are located and how they are performing.

1. On the Home screen, press the upper left corner drop down menu to open the existing structure
2. Select “Home Management”
3. From this screen, you can see the different homes or buildings that are already added, or select “Create new home” to add a new location. Your location should be based on a physical location with a standard postal address.
4. Enter the name and address of the location
5. Below you will see rooms already standard in the location, you may uncheck these if they do not fit with your organizational structure and instead choose “Add Room”
6. Name the room within the location and repeat this for each room that will be cleaned by the co-botic 1700
7. When you add a new device into your organization, make sure to add the device in the correct location AND room that it is assigned to.

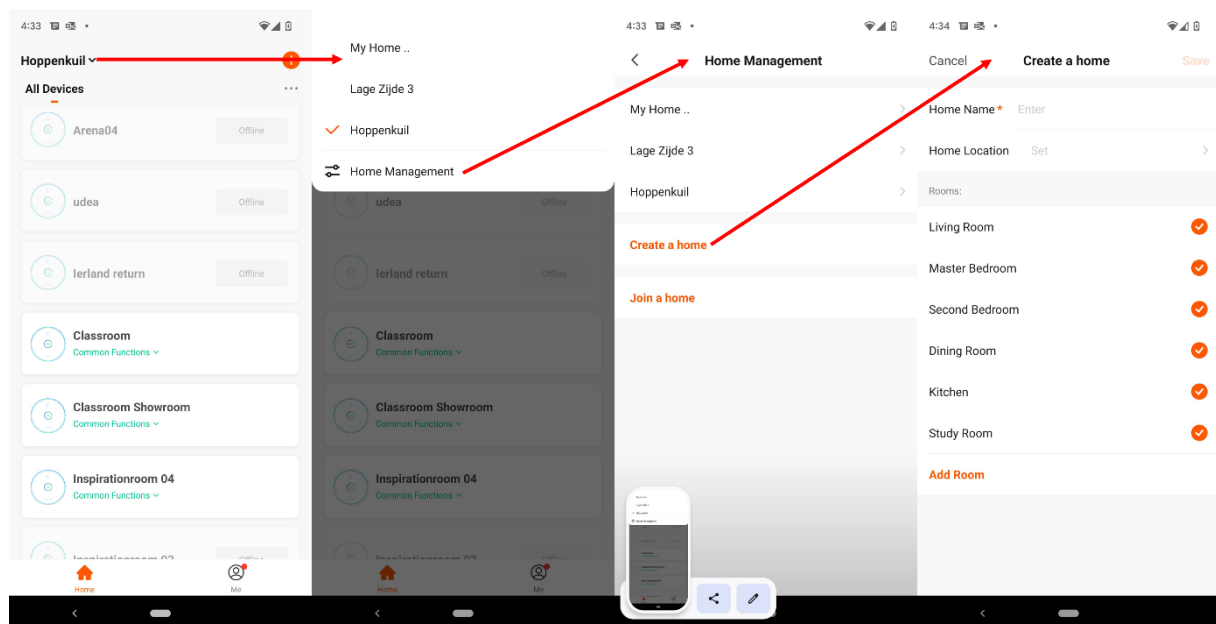

Setting up your organization

6.6 Sharing the co-botic 1700 with multiple users

When setting up multiple users it is important to note that users are created on their individual phones and then they are able to share access to the machines. User accounts are not stored on the machine or in the app. User data is stored in the cloud and then each user can share a single room or the entire organization.

1. Each user should set up their own account on their own app (see Section 6.2-6.3 in this user manual)



2. To share all of the machines at a location/building, you must start from the original account that already has access to the organization.
3. From the home screen, select the location drop down in the top left corner of the screen
4. Select “Home Management”
5. Select the location or building you want to share
6. Press “Add member”
7. A dialog will open and allow you to share a code with others in your organization
8. This code can be shared multiple ways through different messaging apps, or you can copy the code and send it to the correct person
9. When the user receives the code, they should log into their app and then go back to the “Home Management” screen (see steps 3-5)
10. From the “Home Management” screen, select “Join Home”
11. Enter the code from step 7

6.7 Mapping and routes

The co-botic™ 1700 will make its own map as it moves through a space. It will map either when you press the button in manual mode, or when you start it from the app. The maps are stored in the cobot and then accessed from the cobot by the app when needed.

1. Press the green start button and it will change to a pause button. This will cause the cobot to start generating the map.
2. The cobot will begin to clean while it maps and also begin to build the logic for how it will clean in the future.
3. After completion, it will continue to clean in this method every time
4. If you have a preferred cleaning pattern, you may also view and run the pattern by using the “Record” feature to look at past cleanings and maps.
5. To use Record feature, press “More”
6. Select “Record”
7. Select the date and time that you preferred
8. Press “Restore the map”
9. The cobot will load this map and route and run this same cleaning procedure.

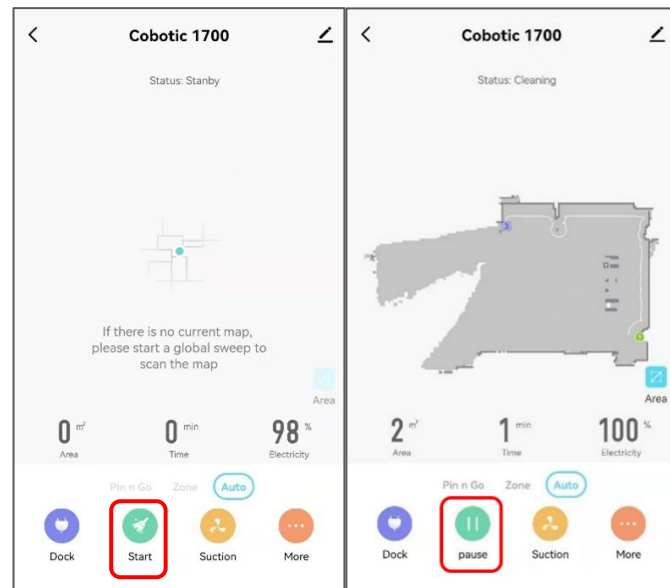

Mapping in progress

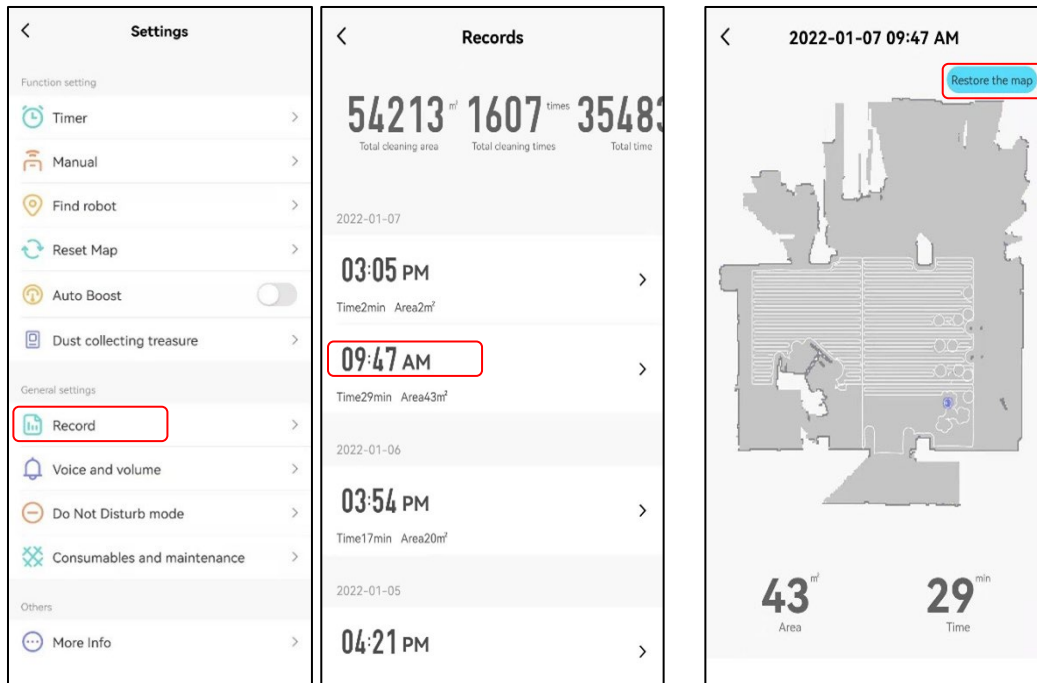

6.8 Creating rooms, no-go zones and cleaning modes

To use zones it is important to understand the three modes of operation: Pin and go, Zone, and Auto

1. To create a no-go zone:

- Open the map that you want to use
- Select "Area" button on the right side of the screen
- Choose "Add area"
- Drag the square around the area that you do not want to cobot to clean. This is especially helpful for doorways or exits that you don't want the cobot to go through.
- You can resize, rotate, and delete the zone from this screen
- Save your zone

2. To create rooms for cleaning



Making a no-go zone



- a. Open the map that you want to use. NOTE: To set up multiple rooms, make sure that you map the entire space including all rooms and hallways leading to the rooms
 - b. Select the “Zone” button below the map
 - c. Select “Create area” button to the right
 - d. Drag the shape of the room out as you prefer
 - e. Name the room using the pencil icon in the lower left corner of the shape
 - f. Press “Start” to save the room
 - g. NOTE: Selecting the “Area” button in this screen works the same as creating a no-go zone, but if you create a no-go zone here, it will also use it for zone cleaning.
 - h. NOTE: Due to network latency, you may not see the rooms and no-go zones right away. Please wait up to 30 seconds when loading the map to see the zones.
3. How cleaning works in the different modes:
- a. Auto – The cobot will clean the entire map starting from the charging station
 - b. Zone – The cobot will clean only the zones that have been created. It will begin cleaning the closest zone to the charger and end cleaning in the room with the charger. You can also select a zone, then press start and it will go directly to that zone.
 - c. Pin and go – The cobot will clean a direct location you choose on the map. It will go to that spot and then clean 1.5 meters radius around the spot.

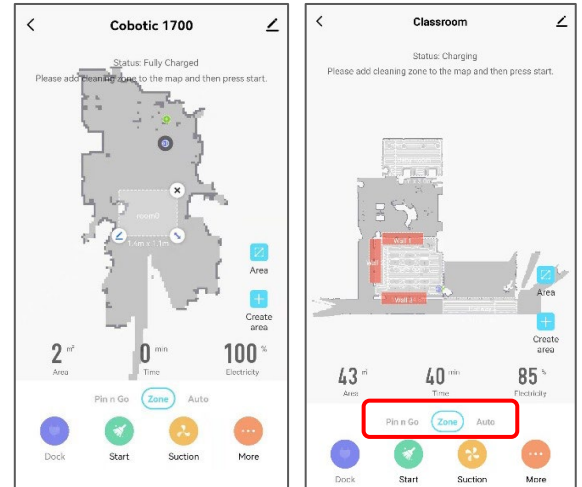

Making rooms and the mode selection



6.9 Using the cleaning buttons

1. The buttons at the bottom of the screen are explained below:
 - a. Dock – Will send the cobot back to its charging base. You can pause the process by pressing this button again
 - b. Start – Will start the cleaning process based on what mode is selected (Pin and go, Zone, or Auto)
 - c. Suction – Controls the power of the vacuum motor. This setting will automatically adjust depending on floor type for optimal cleaning.
 - d. More – Accesses other features described in this manual

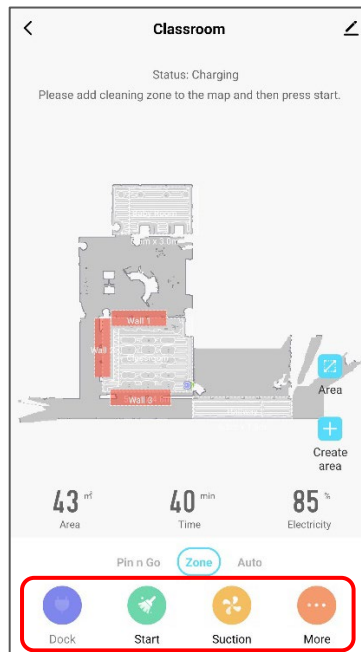

The cleaning buttons

6.10 Other features

These features are found under the “More” button

1. Scheduling cleaning
 - a. Select “Timer”
 - b. Set the dates and times that you would like to schedule the cleaning and if you want to be notified
2. Manual control
 - a. This allows you to move the cobot manually
 - b. NOTE: Due to network latency, there may be a significant delay between pressing the movement button and the actual movement of the cobot. It is advised to use the infrared remote included with the cobot if you would like to manually control it.
3. Find robot
 - a. This feature allows you to find the cobot in your location.
 - b. It will announce “Hey! I’m over here!”

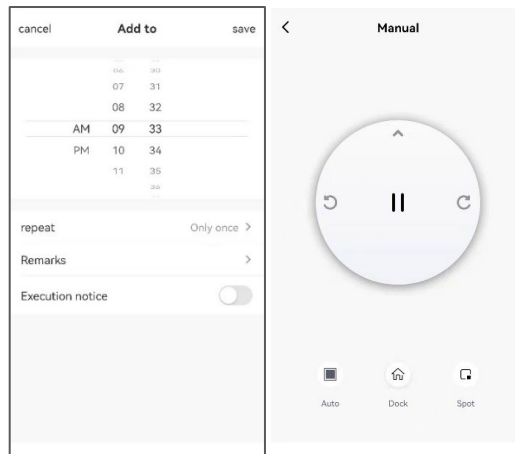

Scheduling and manual control

4. Reset map
 - a. This will delete the contents of your map to start new
5. Auto boost
 - a. This option will allow the vacuum to auto adjust depending on floor type. Turn it off to control the suction level manually
6. Dust collecting treasure
 - a. This option requires you to have the Automatic Dirt Disposal unit
 - b. This option selects the frequency the cobot will empty its contents into the Automatic Dirt Disposal unit (optional)
7. Record
 - a. This option will show you the cleaning record of the cobot including runtime and sq. meter coverage
8. Voice and volume
 - a. This option adjusts the sound levels
9. Do not disturb mode
 - a. This option sets the times that the cobot WILL NOT run so that it doesn't disturb people in the room
10. Consumables and maintenance
 - a. This option allows you to check the levels of the filter, the dust collector, and the roller brush.

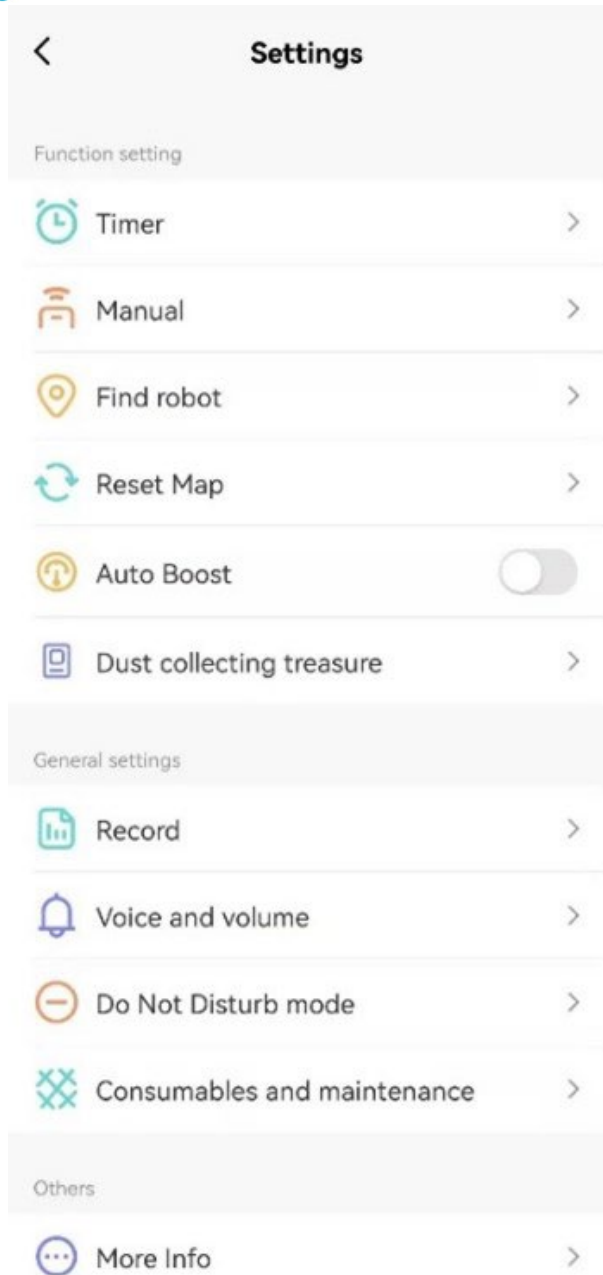

The More menu



7 Maintenance



WARNING

Before you start maintenance or replacing parts; **Turn off the co-botic™ 1700 and remove the battery (if applicable).**

The co-botic 1700 does not require much maintenance. However it is recommended to clean the machine after using it and before storing it. To clean it, simply wipe it down with a dry microfiber cloth. Do not wet the cloth.

For a proper functioning and a long lifespan of the co-botic 1700, it is important to follow the recommended maintenance intervals mentioned in this manual.

Maintenance that is not described in this manual should be done by your co-botic 1700 partner. Please make sure to have the model and serial number of the co-botic 1700 available when you call a partner. For more information please fill out the contact form on www.i-teamglobal.com.

7.1 Cleaning

Clean the exterior of the machine using a dry microfiber cloth.

7.2 Damaged or worn parts

Damaged or worn parts need to be replaced immediately. Contact your local i-team Global partner or visit www.i-teamglobal.com for more information.

7.3 Maintenance frequency

To ensure proper and safe operation throughout the life of the co-botic 1700, it is recommended to have an authorized i-team partner check the machine after the first 50 hours of use and then every 125 hours afterwards.

7.4 Storage

See section 4.



8 Troubleshooting

List of fault codes:

| | |
|-------------------|--|
| dp_robot_fault_1 | Low battery, start recharging |
| dp_robot_fault_2 | Low battery, shut down |
| dp_robot_fault_3 | Abnormal driving wheel / universal/main wheel |
| dp_robot_fault_4 | Does not meet the upgrade conditions, please charge |
| dp_robot_fault_5 | Abnormal collision sensor |
| dp_robot_fault_6 | The designated / appointed area cannot be reached |
| dp_robot_fault_7 | Machine tilted |
| dp_robot_fault_8 | Radar cover is stuck / Laser head cover is stuck |
| dp_robot_fault_9 | Abnormal radar speed / Abnormal laser distance sensor speed |
| dp_robot_fault_10 | Radar data is abnormal / Abnormal sensor data recorded |
| dp_robot_fault_11 | Wall inspection sensor is dirty / TOF Sensor for wall is dirty |
| dp_robot_fault_12 | Dirty sensor along the wall / Infrared anti-collision sensor is dirty |
| dp_robot_fault_13 | Abnormal middle brush / rolling or main brush |
| dp_robot_fault_14 | Abnormal side brush |
| dp_robot_fault_15 | Fan abnormal / Abnormal vent outlet |
| dp_robot_fault_16 | The dust box is removed / taken out |
| dp_robot_fault_17 | Dust box full |
| dp_robot_fault_18 | The dust box does not work when it is take / Does not work when the dust box is removed |
| dp_robot_fault_19 | The dust box is taken out when the dust is full /The dust box is full, remove the dust box |
| dp_robot_fault_20 | The machine is stuck / trapped, it is recommended to set up a forbidden area /no-go zone where the machine got stuck |
| dp_robot_fault_21 | Being picked up at work / The machine is lifted while working |
| dp_robot_fault_22 | The water tank is gone |
| dp_robot_fault_23 | The amount of water is insufficient, please add water |
| dp_robot_fault_24 | Please move out of the restricted area and start again |
| dp_robot_fault_25 | Ask the owner to wipe the cliff sensor, and start it away from the cliff |
| dp_robot_fault_26 | Recharge failed |
| dp_robot_fault_27 | Charging failed |
| dp_robot_fault_28 | Abnormal main wheel / driving wheel |
| dp_robot_fault_29 | Radar anomaly / Abnormal radar/laser distance sensor |
| dp_robot_fault_30 | Pump abnormality / Abnormal water pump |



9 Decommissioning and disposal



ATTENTION

It is the responsibility of the co-botic™ 1700 owner to dispose of the product properly and safely.

At the end-of-life the co-botic 1700 still contains valuable resources and needs to be disposed of according to your local laws and regulations regarding recycling of electrical equipment.



1. If applicable, remove the battery for separate disposal (see section 5.4).
2. Remove all loose components.
3. Dispose of all items according to your local laws and regulations.

TIP:

Contact your local i-team partner to explore all possibilities of returning components at the end-of-life of your co-botic 1700.

10 Specifications and CE

| | |
|------------------------------------|---------------------------|
| Model: | Co-botic™ 1700 (basic) |
| Body size (L x W x H): | 350 x 350 x 98 mm |
| Weight (excl. battery): | Not applicable |
| Weight (incl. battery): | 3.4 kg |
| Power source: | 220V docking station |
| Battery spec i-power x: | Not applicable |
| Run time on battery: | 270 minutes |
| Charger type: | Docking |
| USB-C charging (5 V 2 A) time : | ≈ 240 minutes |
| i-charge 5 time: | Not applicable |
| i-charge 7 time: | Not applicable |



EG/EC
DECLARATION OF CONFORMITY

We: Future Cleaning Technologies B.V., Hoppenkull 27b, 5626 DD Eindhoven, Netherlands

Declare under our sole responsibility that the product: Vacuum cleaner

Co-botic

(Type of machine)

Co-botic 1700, IVAC17.FCT.0230A, IVAC17.FCT.0230C, IVAC17.FCT.0240A, IVAC17.FCT.0240C, IVAC17A and following

(Model – serial number, year of production)

to which this declaration relates is in conformity with the following standards,

IEC 60335-2-2:2019; IEC 60335-1:2010+A1+A2 COR1:2010, COR2:2010, AMD1:2013, COR1:2014, AMD2:2016, COR1:2016

(Title and/or number and data of issue of the standard(s) or other normative document(s))

follow the provision of directives:

EMC 2014/30/EU, Machinery 2006/42/EU, ROHS 2011/65/EU, EU 2015/836 Annex II

Eindhoven, 15.02.2022

Frank van de Ven
Director

(Place and Date of issue)

(name and signature or equivalent marking
or authorized person)



The i-Story

It's not just about cleaning machines.

It's about the well-being of people and the planet.

We are stoked about cleaning, thrilled about sustainability and wholeheartedly dedicated to keep on innovating.

We believe effective cleaning is more than 'just' the removal of soil. It means ensuring the health and safety of people, while making the job easier, simpler, more efficient and even fun. It means consistent results all over the world, while protecting the world. And it means creating partnerships to grow our global force for better cleaning. After all, it takes a team.

The i-team.

Made Blue

By operating i-mops, your partners, clients and users lower the water footprint whilst contributing positively to the availability of water in the world. Every day an i-mop is turned on, Made Blue simultaneously ensures someone else on the planet gets access to clean water. For every litre that the i-mop uses in operations, the i-team and Made Blue mirror clean drinking water in a developing country. The planet is a beautiful place with over 7 billion people. Humans need water to live, breathe, and enjoy their lives. Worldwide 2,7 billion people suffer from a shortage of drinking water. For 780 million people this situation is permanent: each year 3,5 million people die because of this. That's why Made Blue invests in projects in developing countries. We are a proud partner of Made blue. Made Blue mirrors the water used by i-team to create clean water in developing countries. 1 litre for 1 litre.



MADE BLUE



Access to clean water for **All.**



This page left intentionally blank



i-team Professional B.V.

Hoppenkuil 27b, 5626 DD Eindhoven, The Netherlands

Telephone: +31402662400

Email: hello@i-teamglobal.com

Internet: www.i-teamglobal.com